



INSTRUCTION GUIDE FOR:

Goosebox
94920 / 94980

Date of Purchase: / /

SCAN NOW TO LEARN MORE
Use your smart device to scan the QR code
and get the latest:

- Instructions manual
- How-to videos
- News on our products



ENGLISH

These instructions contain IMPORTANT safety information. Please read and keep for future reference.

WARNING

Under no circumstances should the towing vehicle manufacturer’s recommended vehicle towing capacity be exceeded. Failure to follow instructions for installation and use may cause property damage, injury or death.

READ ALL INSTRUCTIONS BEFORE STARTING THE INSTALLATION OR USE.

94920 – 20K Goosebox

20,000 lbs. Rating
4,000 lbs. Max Pin Weight

94980 – 22.5K Goosebox

22,500 lbs. Rating
4,000 lbs. Max Pin Weight

Tools and Equipment Required to Install:

- Fastener kit 94621F (For 94920 and 94980)
(Included)
- 15/16” socket
- 15/16” wrench
- Torque wrench capable of going to 250 ft-lbs.
- Lithium grease

SAFETY INSTRUCTIONS

- Equipment for lifting approximately 250 lbs.

What’s Included:

- 20K / 22.5K Goosebox
- Fastener Kit (94621F)
 - Hex Bolt – GR8 - 5/8”-11x2.00” – QTY 8
 - Conical Washer – 5/8” – QTY 8
 - Flat Washer – 5/8” – QTY 8
 - Hex Nut – GR8 - 5/8”-11 – QTY 8

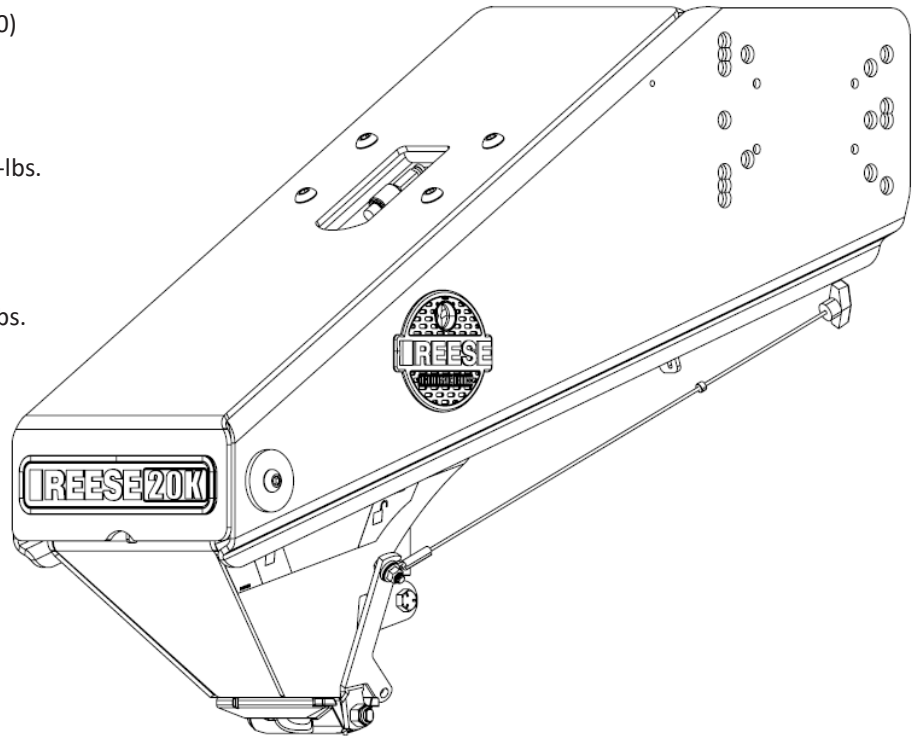

Table of Contents

Safe Towing.....p 2
 Trailer Guidelines.....p 3
 Product Warnings.....p 4
 Hitching/Unhitching.....p 7
 Matching Wing Setsp 9

Typical Bolting.....p 12
 Air Fill/Adjustment.....p 13
 Maintenance.....p 15
 Locking Instructions.....p 16
 Warranty.....p 17

SAFETY INSTRUCTIONS

- Fully understand the manufacture's tow ratings of the truck being used.
- Do not exceed these ratings.
- Ensure rearview mirrors are properly adjusted.
- Ensure brake controller is properly adjusted and operating correctly.
- Take wide turns to ensure proper clearance between trailer and obstacles.
- Ensure breakaway switch is securely mounted and free from obstructions.
- Cable should be free of snags through full turning radius.
- Ensure safety chains (if equipped) are securely mounted and free from obstructions.
- Chains should be free of snags through full turning radius.
- All coupling surfaces should be clean of dirt and debris, and lightly greased.
- Use E-rated tires.
- Ensure tires are properly inflated.
- Airbags (if equipped) should be inflated to the proper pressure.
- Truck should be level when trailer is attached and loaded.
- Clearance between top of bed sides and underside of trailer nose should be approximately 7 inches.
- Allow more clearance if using in off-road applications.
- Truck and trailer should be loaded evenly and to not exceed manufacturer's rating.
- Do not load trailer heavier behind axle(s).
- Overloading may result in serious personal injury or death, vehicle crash, and/or property damage.



Failure to check and follow tow ratings could result in tow vehicle damage or truck and trailer separation while towing.

- Trailer and its contents together must not exceed truck, hitch and/or trailer tow ratings.
- Towing vehicle must have a manufacturer's rated towing capacity equal to or greater than the gross trailer weight (dry weight of the trailer plus payload of the trailer) (Figure 1).
- Gross weight of trailer must not exceed 20,000 pounds for part number 94920 or 22,500 pounds for part number 94980.
- Gooseneck ball vertical weight (Pin Weight) must not exceed 4,000 pounds for part number 94920 and 94980 (Figure 2).

Figure 1

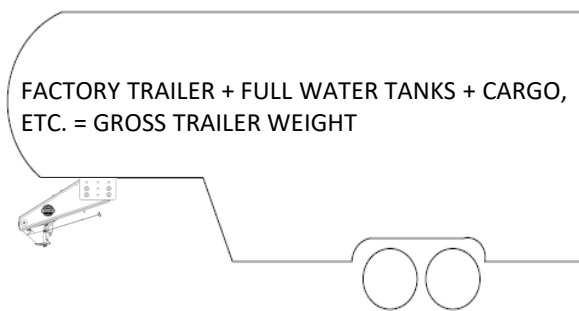

1. Check Tow Ratings:

Vehicle Tow Rating: _____.

Goosebox Rating: 20,000 lbs.

Goosebox Rating: 22,500 lbs.

*Gross Trailer Weight (Figure 1): _____.

***Gross trailer weight should be the lowest of these recorded ratings for safe towing conditions.**

Figure 2

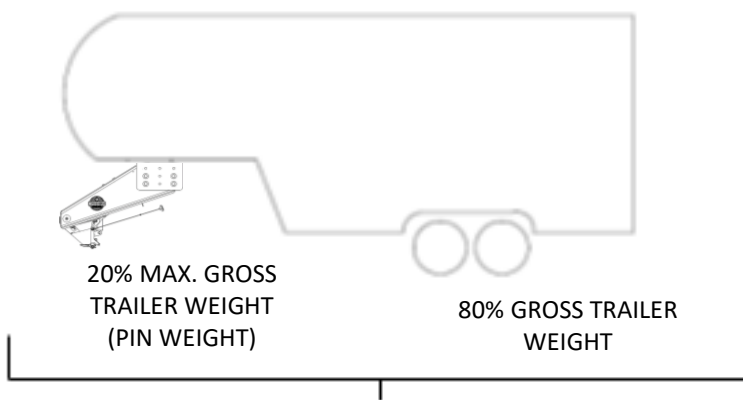

2. The Goosebox is designed for a maximum of 20% Gross Trailer Weight on the gooseneck ball (Vertical Pin Weight) (Figure 2).

 CAUTION

Due to Vehicle and RV Trailer variations, it is necessary to check the rear bumper to trailer clearance. If the clearance is less than 2 feet, this check can be done after installation by making a slow turn, in a controlled driving environment (i.e. closed parking lot, grass field, etc.) with the aid of an observer to watch for interference.

II. Bumper Clearance

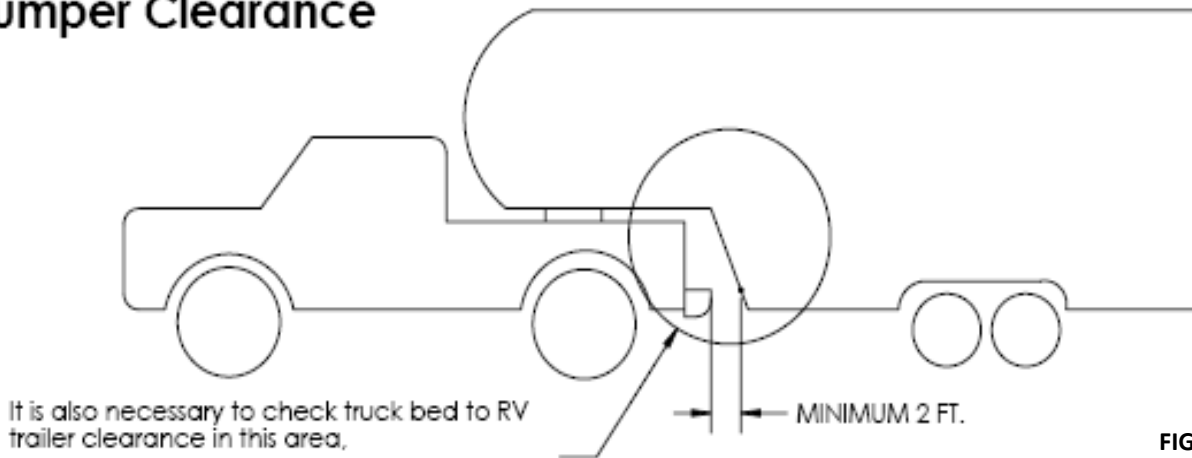

FIGURE 3

3. A minimum clearance between the bumper and trailer (Measured at the same height) of 2 ft. is recommended (Figure 3).

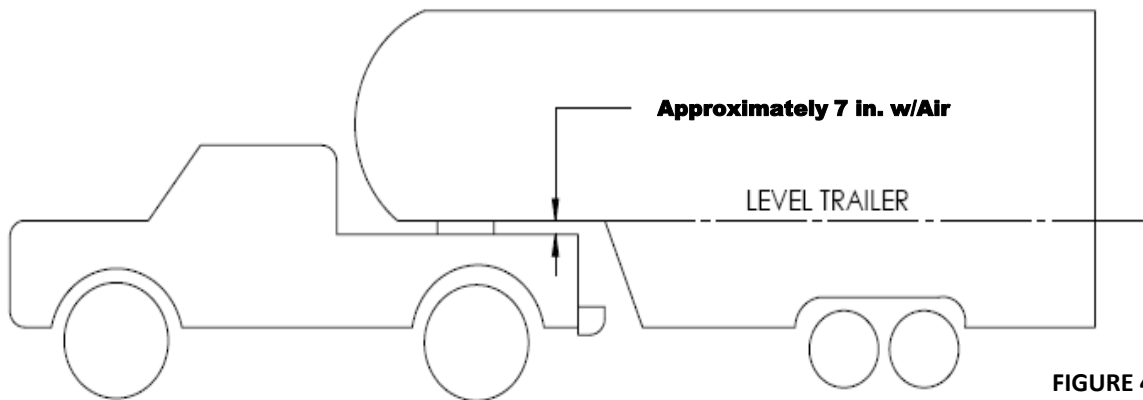

FIGURE 4

4. The height of the Goosebox should be adjusted such that the trailer is approximately level as it is towed. Allow approximately 7 inches clearance between the top of the bedside and the underside of the front of the trailer for pitch and yaw of the trailer (Figure 4).



For off-road use, monitor closely and allow more clearance between pickup bedsides and trailer

 CAUTION

The measurements in figures 3, 4 & 5 are guidelines; if your measurements are close to these numbers, re-check clearances. If vehicle and/or trailer has any added vanity accessories (i.e., fairings, air dams, ground effects, bed rails, etc.) additional dimensioning and clearance checks must be made. Horizon Global is not responsible for damage incurred due to disregarding these clearance checks.

Lippert 1621 (2 mounting positions that provide 2 inches of adjustment)

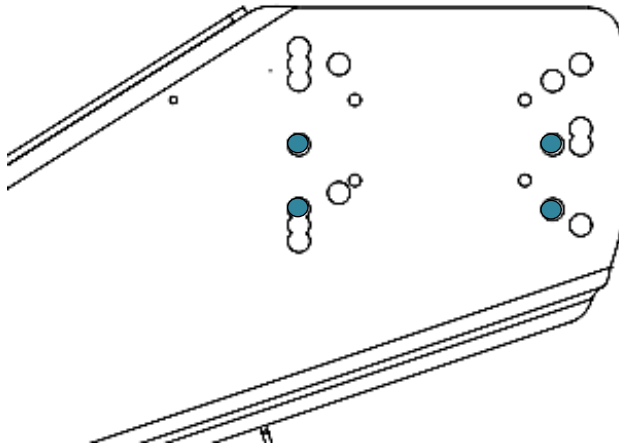

Bolt Locations

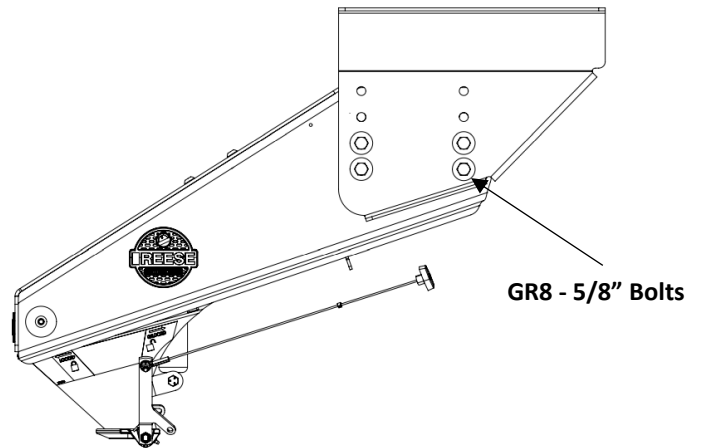

GR8 - 5/8" Bolts

Trailer Forward

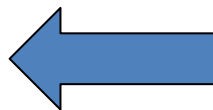
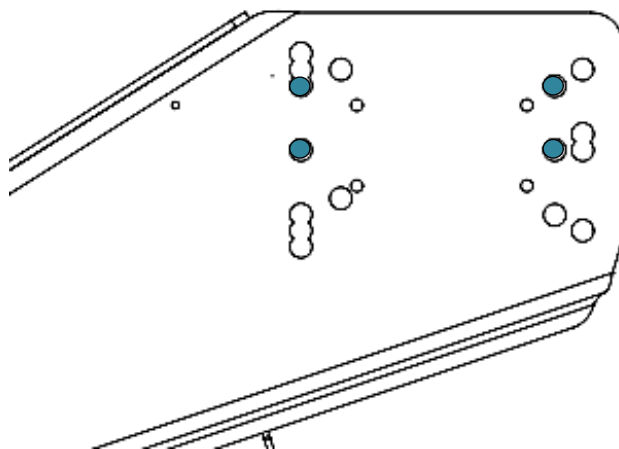
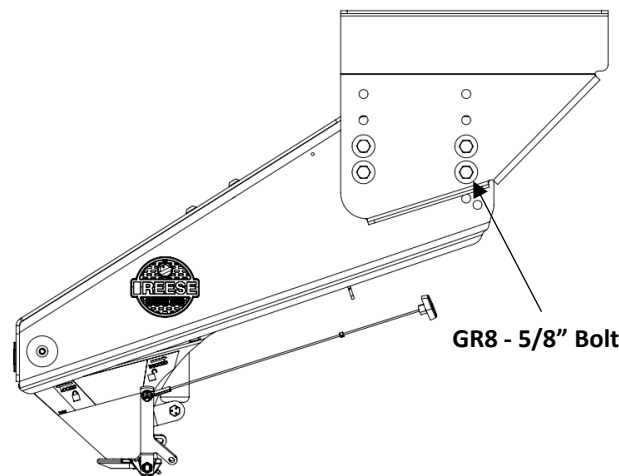

Figure 5:
Lippert 1621 Standard Mounting Position



Bolt Locations



GR8 - 5/8" Bolts

Trailer Forward

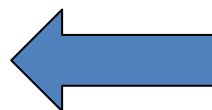
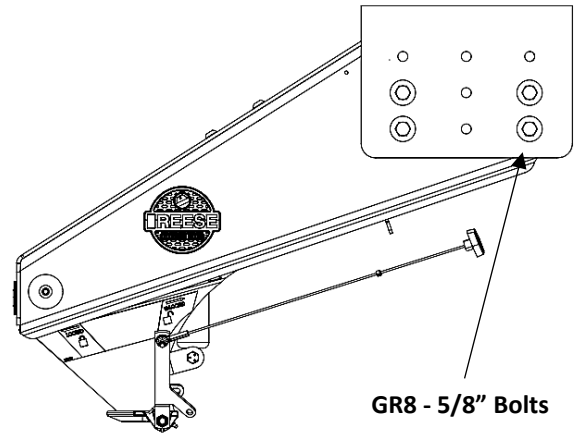
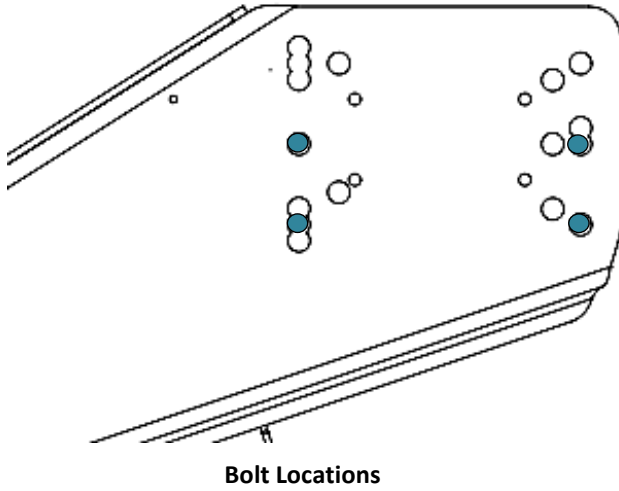

Figure 6:
Lippert 1621 Lowest Mounting Position

NOTE: For other wing sets, please

- Visit <https://qr.towingproducts.net>
- Or call Technical Service at: 1-800-632-3290

Lippert 1716 (2 mounting positions that provide 2 1/2 inches of adjustment)



Trailer Forward

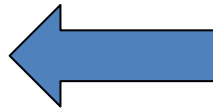
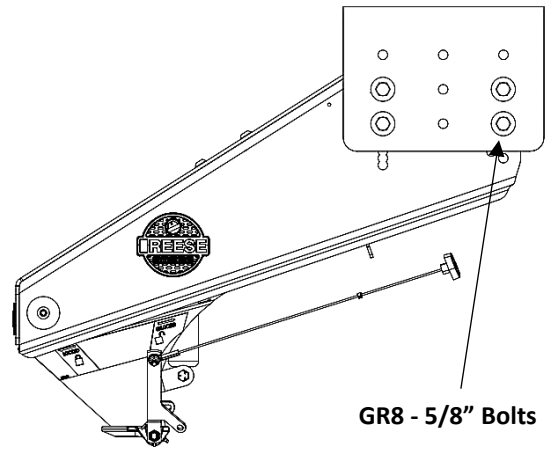
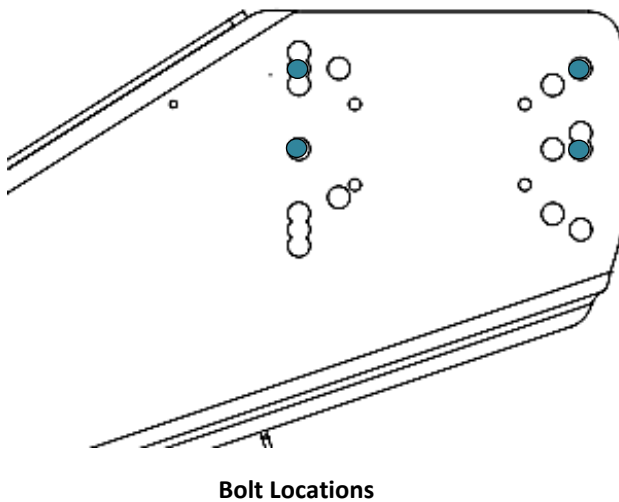

Figure 7:
Lippert 1716 Standard Mounting Position



Trailer Forward

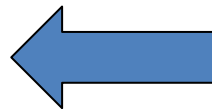

Figure 8:
Lippert 1716 Lowest Mounting Position

- NOTE:** For other wing sets, please
- Visit <https://qr.towingproducts.net>
 - Or call Technical Service at: 1-800-632-3290

Lippert Rhino (1 mounting position)



Rhino bolt hole application has a maximum load of 20,000 lbs.

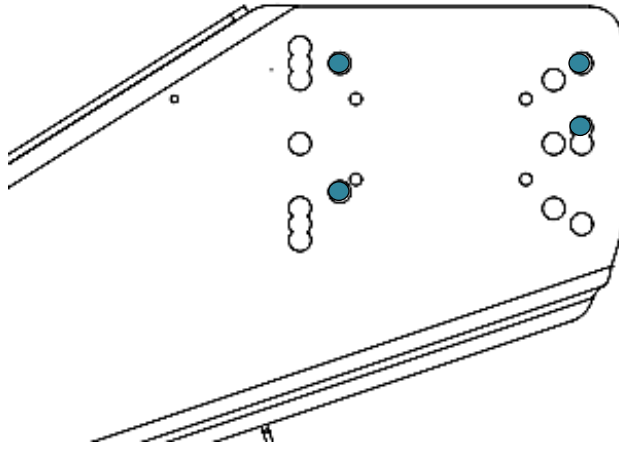

Bolt Locations

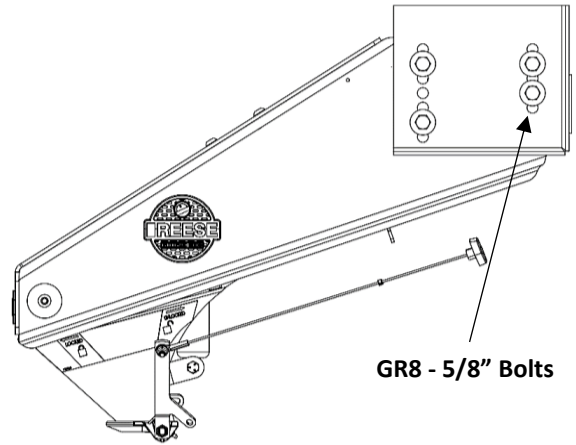

GR8 - 5/8" Bolts

Trailer Forward

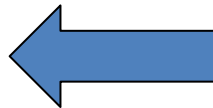

Figure 9:
Lippert Rhino Mounting Position

NOTE: For other wing sets, please

- Visit <https://qr.towingproducts.net>
- Or call Technical Service at: 1-800-632-3290



WARNING: During installation, be mindful of clearances, wiring and other obstructions. When torquing fasteners, please use caution to not distort vehicle structure.

NOTE: The Figure Shows a Typical Installation.

The trailer wing is moved away to better show the hardware installation.

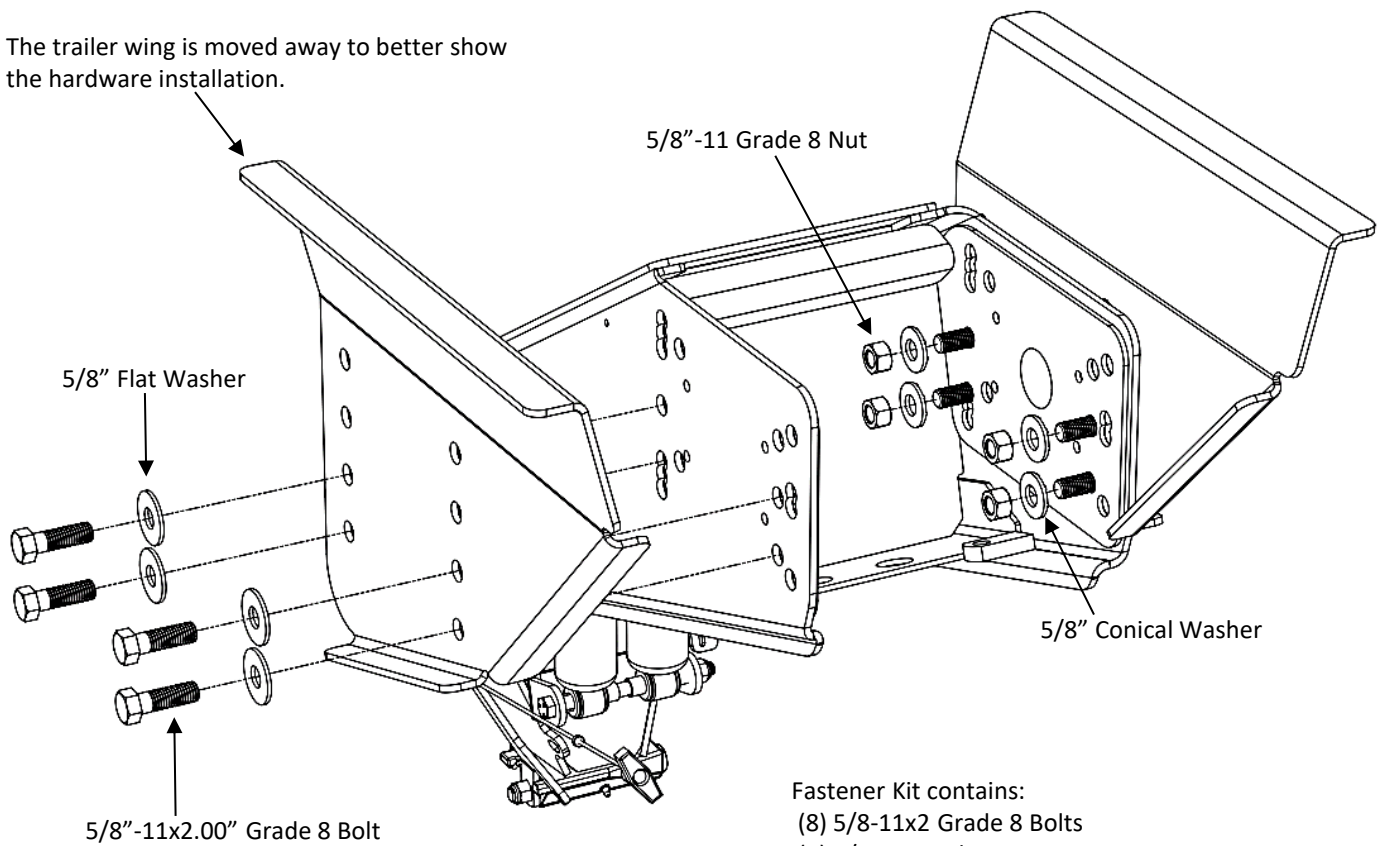

- Fastener Kit contains:
- (8) 5/8-11x2 Grade 8 Bolts
 - (8) 5/8-11 Grade 8 Nuts
 - (8) 5/8 HD Flat Washers
 - (8) 5/8 Conical Lock Washers

Figure 10

Bolts & flat washers are installed from the outside, conical lock washers and nuts on the inside.



Torque Bolts To 210 ft-lbs.

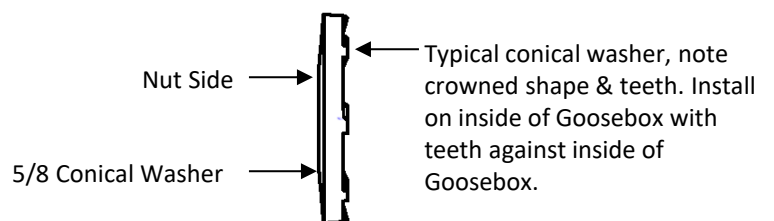
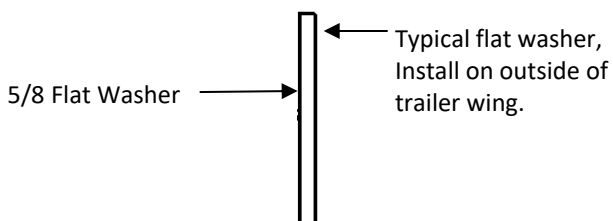



Goosebox has multiple pinch points that can cause serious injury. Keep fingers and all other body parts away from any of the listed pinch points. Placing a body part or object anywhere else, except the air inflation valve could damage or serious injury.

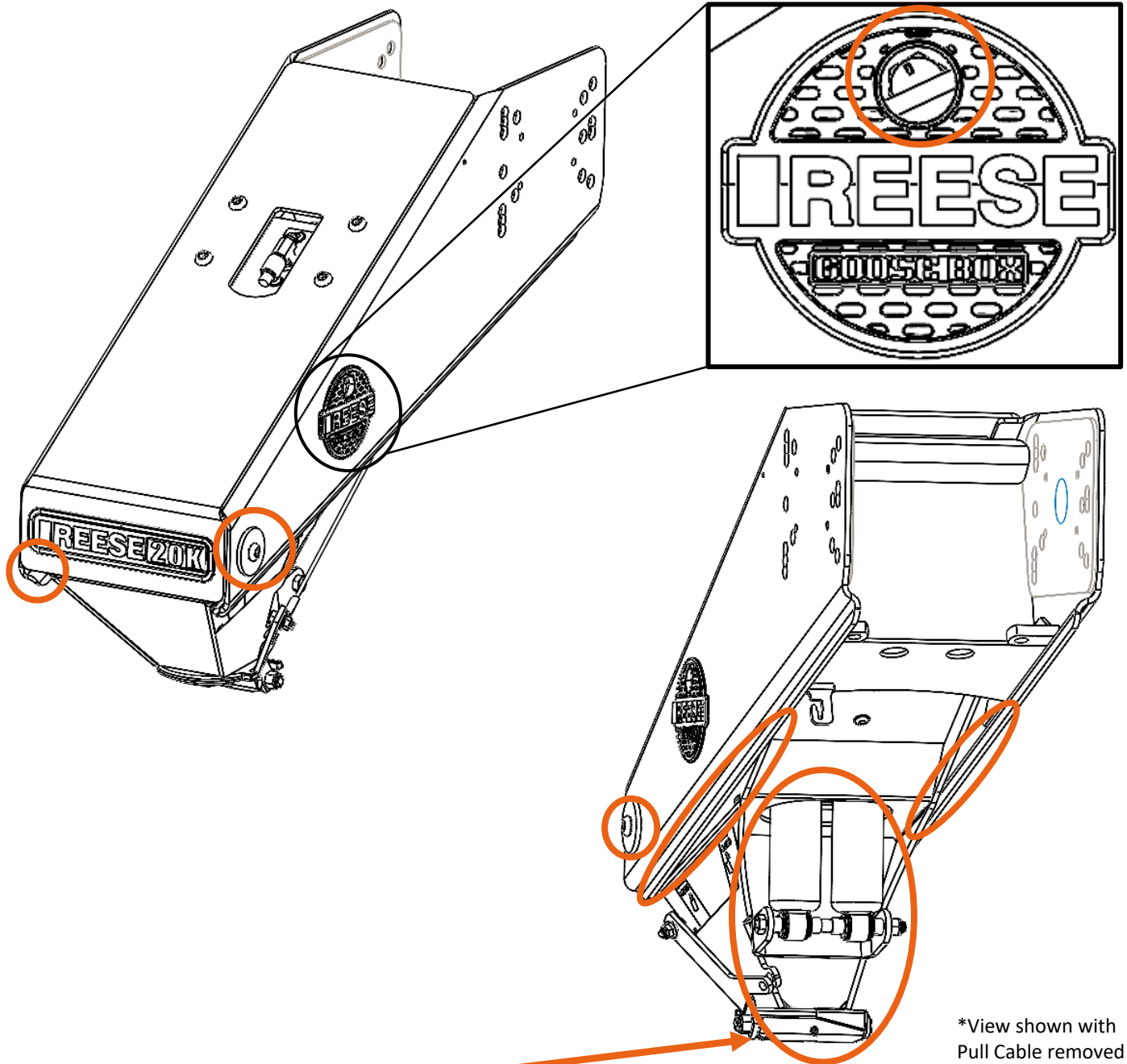

Coupler may have sharp edges

*View shown with Pull Cable removed

Figure 11



Failure to follow this instruction may result in the coupler being too high and coming to rest on top of the gooseball. This could result in trailer separating from the truck. Trailer separation may result in death or serious injury if anyone is under the trailer or between truck and trailer when separation occurs.

HITCHING:

1. Place blocks (sometimes called “chocks”) firmly against front and rear of each trailer tire to prevent any possible forward or rearward motion. DO NOT REMOVE BLOCKS UNTIL EACH OF THE FOLLOWING STEPS AND THE PULL TEST HAVE BEEN COMPLETED. Lower tailgate if necessary. Clearance of the lowered tailgate to the trailer needs to be monitored during hookup as some manufacturer combinations of truck and trailer have little or no clearance.

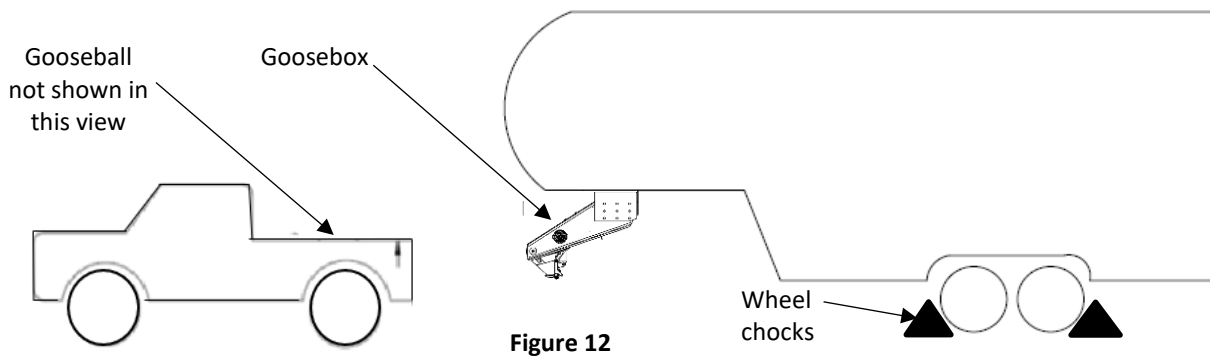

Figure 12

IMPORTANT: YOU ARE RESPONSIBLE FOR SAFE HITCHING AND UNHITCHING OPERATIONS. DO NOT RELY ON OTHERS TO PERFORM THESE DUTIES. YOU MUST PERSONALLY MAKE SURE THE FOLLOWING STEPS ARE PERFORMED IN THE FOLLOWING ORDER!

3. Ensure that the Gooseball is locked within the housing of the truck bed. Use only with 2 5/16” diameter gooseneck ball.
4. Ensure coupler handle is in the locked position and not limited by the pull cable or debris (Figure 12).
5. Back the truck into trailer slowly until the coupler of Goosebox is above the gooseball .
6. Lower coupler onto gooseneck ball. The Goosebox coupler handle will open, then snap shut.
7. Make certain handle has returned forward and is in the locked position before towing.

NOTE:

1. Visually inspect from the side of your vehicle that the gooseneck ball is completely recessed inside the Goosebox coupler.
2. After the handle is in the locked position, raise the trailer jacks to ensure the Goosebox is locked onto the gooseneck ball.

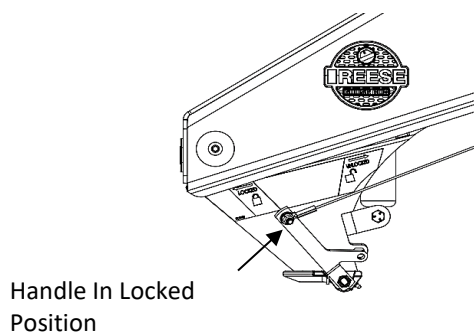

Handle In Locked Position

Figure 13

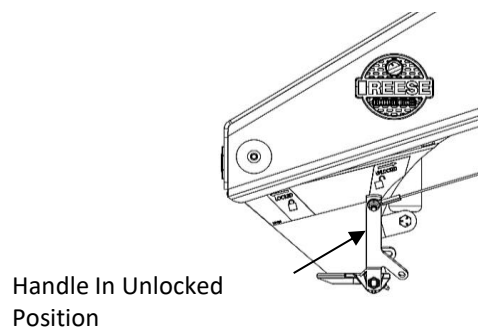

Handle In Unlocked Position

Figure 14



Unstable or improperly hitched trailers can fall or separate and cause serious injury or death:

- **NEVER** attempt to hitch trailer without first reading and following all instructions in the manual provided with this product. Do not use without reading and understanding the manual.
- **NEVER** tow a trailer that exceeds all rated capacities. Towing a trailer that exceeds all rated capacities can result in trailer separation, serious injury, or death. The combined weight of the trailer and its contents must not exceed the lowest truck, hitch, and trailer weight and tow rating
- **NEVER** allow any part of the body to be placed under the trailer or between the truck and trailer.
- Keep hands clear when operating coupler mechanism.

UNHITCHING:

PERFORM THE FOLLOWING IN THIS ORDER:

1. Ensure truck is in park with emergency brake on.
2. Place blocks firmly against front and rear of each trailer tire to prevent any possible forward or rearward motion.
3. Lower trailer landing gear following the directions in the Trailer Manual until feet of landing gear are resting on firm ground.
4. Lower truck tailgate.
5. Disconnect power cable and breakaway switch cable between truck and trailer.
6. Using pull cable, pull handle back and hook cable stop onto the bracket. Handle should be in the Unlocked position (Figure 14).

NOTE: If necessary, adjust the cable stop by loosening the small set screw (Allen wrench size is 0.050"), moving the cable stop, and then retightening.

7. Raise trailer until bottom of coupler is approximately one inch above top of gooseneck ball, then release cable.
8. Ensure coupler latch returns to locked position.



Filling the Goosebox air system may require 2 people. One person will need to fill the system while the other watches the air inflation visual indicator. Horizon Global advises against filling the air system with only one person.

Before filling the air system, perform these safety steps and ensure:

1. Ensure that you are 100% coupled, coupler latched and locked. Refer pages 7 and 8 for hitch and locking procedures.
2. Ensure that your trailer and tow vehicle are on level ground with your vehicle in park and the park brake applied.
3. Ensure that the tow vehicle and trailer are secured i.e., Have blocks (chucks) that are positioned firmly against front and rear of each towing vehicle and trailer tire to prevent any possible forward or rearward motion. DO NOT REMOVE BLOCKS UNTIL EACH OF THE AIR FILL STEPS HAVE BEEN COMPLETED.

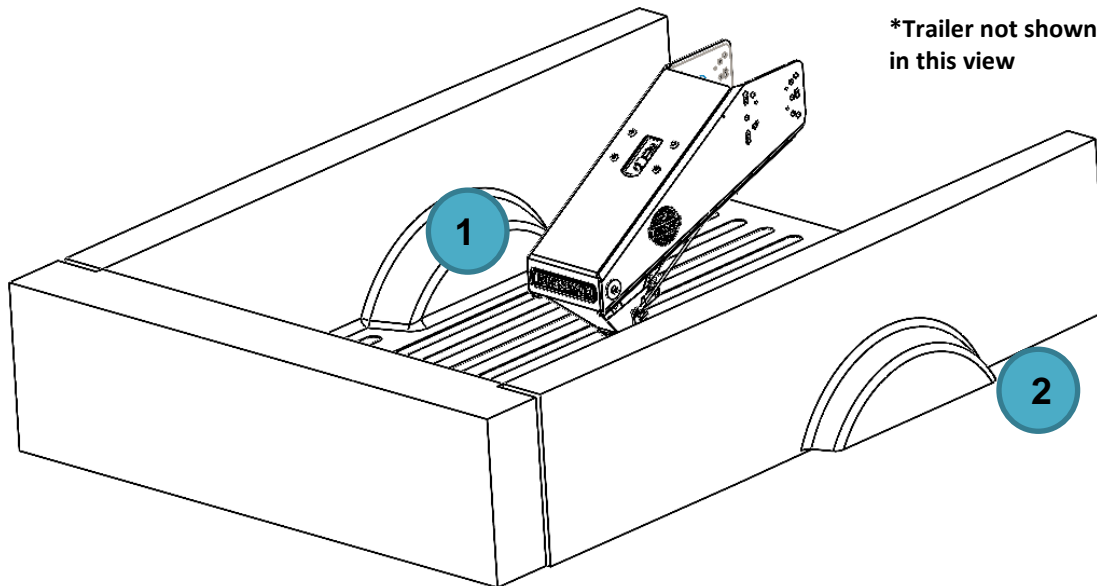

Figure 15

When filling the air system, 2 people may be required:

1. One person should be in the truck in order to fill the air valve (shown at position 1 of figure 15)
2. The second person should be standing outside of the truck watching the air inflation visual indicator. (Shown at position 2 of figure 15).



DO NOT PUT ANYTHING IN THE INDICATOR.

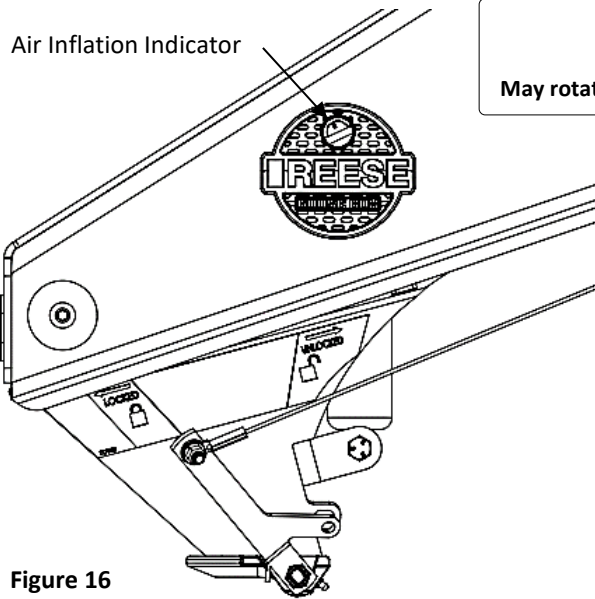

Figure 16

WARNING
 May rotate up to 7 degrees in either direction. Rotation does not affect functionality.

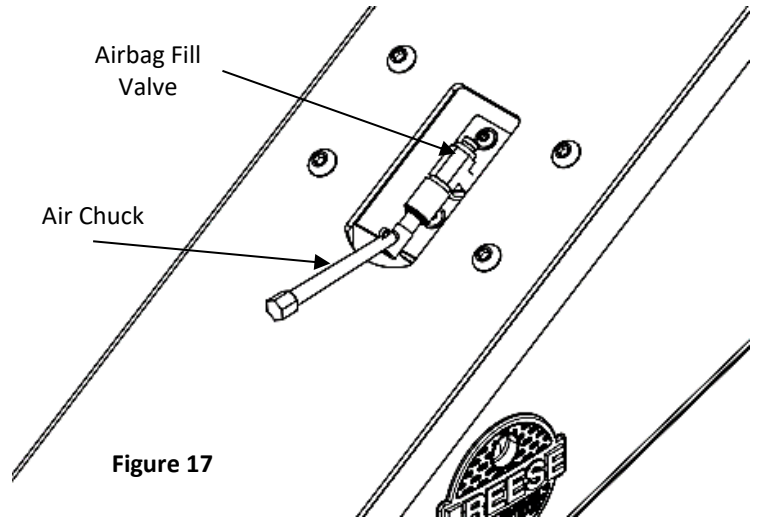

Figure 17

ADJUSTING THE AIR SPRING:

1. Perform the safety steps on page 7 before adjusting suspension air pressure, with the trailer loaded.
2. With trailer hitched to truck and landing gear/jacks retracted, add air to the airbag fill valves as shown in figure 17.
NOTE: Air should **only** be added with air chuck in location shown in figure 17.
3. One person will fill the Goosebox at the inlet. The second person will watch until int is at its nominal position (Seen in the air inflation visual indicator) (Figure 18)
4. Re-check Air inflation indicator and inflate to desired ride comfort position.

NOTE: The Goosebox airbag fill valve is equipped with an automatic air relief valve. If the airbag is over inflated, the relief valve will activate and released air to a safe level.

WARNING

Do not insert fingers or any body parts into the air inflation indicator. Doing so may result in serious injury. It is unsafe to put anything into the visual indicator.

Figure 18:
 Nominal Air
 Position



Figure 19:
 Maximum Air
 Position



Figure 20:
 Low Air
 Position



To ensure long term performance, it is recommended to follow the following maintenance:

1. Grease coupler shaft from fitting on backside of coupler before each use (Figure 21).
2. Clean and grease the Gooseneck ball.
3. Grease the main pivot shaft from fitting on inner bushing before each use (Figure 22).

NOTE: Deflating the airbag may make accessing grease fitting easier.

4. Inspect the Goosebox for any damage or excessive wear.
5. Once per season, fully deflate the airbag and the refill.
6. Perform normal maintenance when taking out of storage.

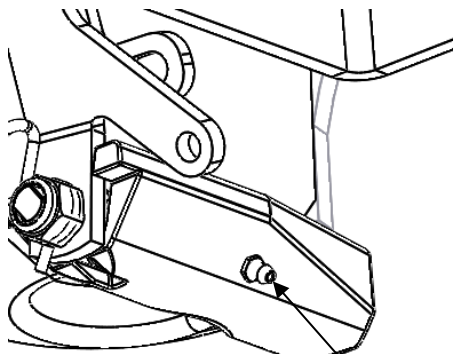
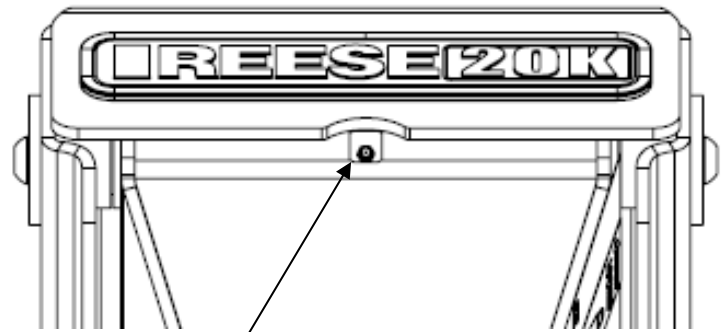

Figure 21

Grease Fitting



Grease Fitting

Figure 22

BEFORE EACH TRIP:

1. **CHECK YOUR EQUIPMENT:** Check the condition of all towing equipment and keep it in proper working condition.
2. Check to see that all bolts and nuts are properly tightened.
3. Check that the airbag pressure is set for your vehicle and loaded trailer.

NOTE: The airbag can lose pressure with temperature changes when not in use.

4. Check the functionality of the coupler pull handle to make sure it moves in both the locked and unlocked positions.

SAFETY CHAIN HANGERS

For added safety, please use the Reese 20K and 22.5K Rated safety chain (part number 49151).

When not in use, put the safety chain hooks into the supplied safety chain holes for proper storage.

Figure 23

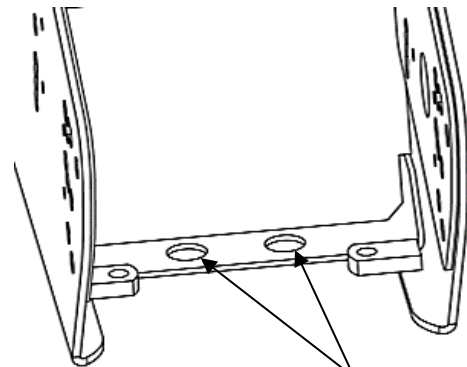

Safety Chain Hanger Location

OPTIONAL LOCK LOCATION:

When hitched up or when the trailer is in storage, a lock may be used for theft prevention in the lock location shown in Figure 24. A commonly available lock that meets the dimensions in Figure 25 may be used (Example: Master lock #5).

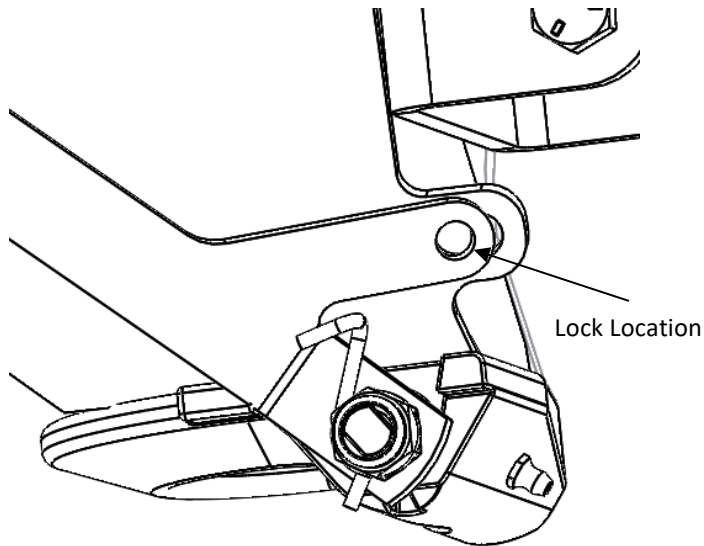

Figure 24

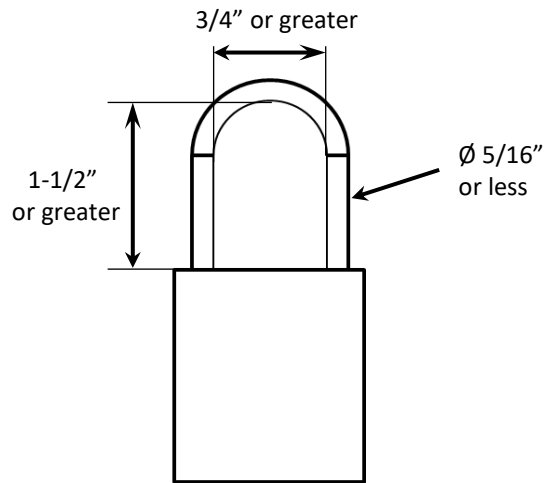

Figure 25

BREAKAWAY SWITCH MOUNTING LOCATION

To help ensure a safe towing experience, a breakaway switch can be mounted in the location shown in Figure 26. The breakaway switch can be mounted on the left or right side of the Goosebox.

NOTE: The breakaway cable should be long enough to allow for full turning radius of the truck and trailer.

Breakaway Switch Mounting Location

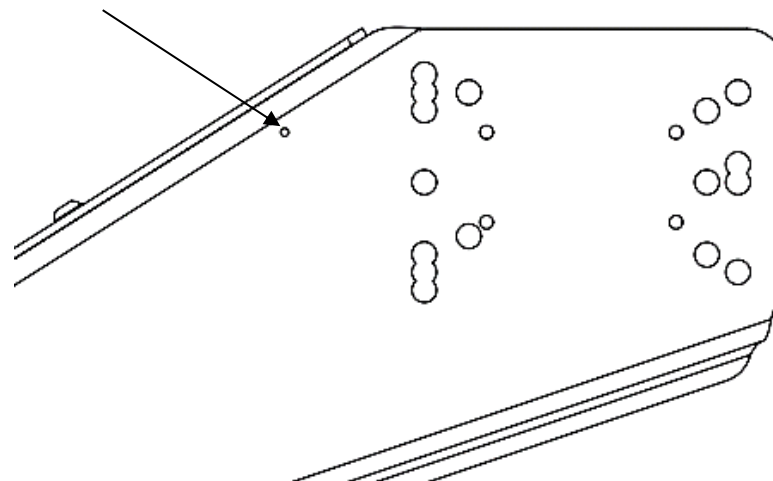

Figure 26



Failure to heed warning and follow instructions may result in serious personal injury or death, vehicle crash, and/or property damage.

- Do not modify.
- Do not tow one trailer behind another (Tandem Towing), this may cause loss of control.

TOWING EQUIPMENT OWNERS

Make sure all operators of equipment read and understand this information before towing. Save for reference. This will help ensure proper use and maintenance of towing equipment. Refer to owner's manuals for tow vehicle, trailer and other parts of the towing system. Learn the capabilities and limitations of each part. GROSS TRAILER WEIGHT and PIN WEIGHT are the two most important items to consider.

THESE WEIGHTS MUST NEVER EXCEED THE LOWEST RATING OF ANY PART OF THE TOWING SYSTEM

GROSS TRAILER WEIGHT is the weight of the trailer plus cargo. Measure GROSS TRAILER WEIGHT by putting the fully loaded trailer on a vehicle scale. PIN WEIGHT is the downward force exerted on the gooseneck ball by the Goosebox. Use a vehicle scale to measure PIN WEIGHT with the fully loaded trailer on a level surface and the Goosebox at normal towing height.

TRAILER COUPLING

The gooseneck ball and coupler should be smooth, clean and lightly lubricated. Adjust per manufacturer's instructions.

SAFETY CHAINS

Connect safety chains properly EVERY TIME YOU TOW. Leave only enough slack to permit full turning. Too much slack may prevent chains from maintaining control if other connections separate.

TRAILER LIGHTS, TURN SIGNALS, ELECTRIC AND BREAKAWAY SWITCH CONNECTIONS

Make these safety-critical connections EVERY TIME YOU TOW, no matter how short the trip. Check operation, including electric brake manual control, before getting on the road.

TIRE INFLATION

Check often. Follow tow vehicle and trailer manufacturer's recommendations.

CHECK YOUR EQUIPMENT/REPLACE WORN PARTS

Check gooseneck ball, coupler, chains, and all other connections EVERY TIME YOU TOW. Re-check at fuel and rest stops.

NO PASSENGERS IN TRAILER!

NEVER allow people in the trailer while towing, under any circumstances.

TRAILER LOADING

Place heavy objects on the floor ahead of the axle. Balance the load side-to-side. Secure it to prevent shifting. **NEVER** load the trailer rear heavy. **LOAD THE TRAILER HEAVIER IN THE FRONT, BUT NOT GREATER THAN PIN WEIGHT RATING.**

DRIVING

The additional weight of a trailer affects acceleration, braking and handling. Allow extra time for passing, stopping, and changing lanes. A gooseneck trailer requires a large turning radius as the trailer tracks to the inside of turns. Severe bumps can damage towing vehicle, hitch and trailer. Drive slowly on rough roads. **STOP AND MAKE A THOROUGH INSPECTION IF ANY PART OF THE TOWING SYSTEM STRIKES THE ROAD. CORRECT ANY PROBLEMS BEFORE RESUMING TRAVEL.**



Part Number Purchased:
Place of Purchase:
Date of Purchase:
Part Manufactured Date (located on driver-side sticker):

NOTES:

Product Registration: www.reeseprod.com/support/products/registration

LIMITED ONE YEAR WARRANTY

- Limited Warranty ("Warranty").** Horizon Global Corporation. ("We" or "Us") warrants to the original consumer purchaser only ("You" or "Your") that the product will be free from material defects in both material and workmanship for a period of one-year, ordinary wear and tear excepted. The Warranty is valid only if (a) the products are returned to Us for inspection and testing; (b) Our inspection discloses to Our satisfaction that any alleged nonconformance are material and have not been caused by misuse, neglect, wear and tear, improper installation, unsuitable storage, improper repair, alteration, or accident; and (c) the products were installed, maintained, and used in accordance with Our instructions. THE WARRANTY IS MADE IN LIEU OF ALL OTHER WARRANTIES, EXPRESS OR IMPLIED (OTHER THAN THE WARRANTY OF TITLE AS PROVIDED BY THE UNIFORM COMMERCIAL CODE IN EFFECT IN MICHIGAN), INCLUDING WITHOUT LIMITATION, ANY WARRANTIES OF MERCHANTABILITY OR FITNESS FOR A PARTICULAR PURPOSE, SAID WARRANTIES BEING EXPRESSLY DISCLAIMED.
- Obligations of Purchaser.** To make a Warranty claim, contact Us, at our principal address of 127 Public Square Suite 5300, Cleveland, OH, 44114, 1-800-632-3290, identify the product by model number, and follow the claim instructions that will be provided. Any returned product that is replaced by Us becomes our property. You will be responsible for return shipping costs. Please retain your purchase receipt to verify date of purchase and that You are the original consumer purchaser. The product and the purchase receipt must be provided to Us in order to process Your Warranty claim.
- Remedy Limits.** Product replacement is Your sole and exclusive remedy under this Warranty. We shall not be liable for service or labor charges incurred in removing or replacing a product. IN NO EVENT WILL WE BE RESPONSIBLE FOR ANY INDIRECT, SPECIAL, CONSEQUENTIAL OR PUNITIVE DAMAGES.
- Assumption of Risk.** You acknowledge and agree that any use of the product for any purpose other than the specified use(s) stated in the product instructions is at Your own risk.
- Governing Law.** This limited warranty gives You specific legal rights, and You also may have other rights which may vary from state to state. This limited warranty is governed by the laws of the State of Michigan, without regard to rules pertaining to conflicts of law. The state courts located in Cuyahoga County; Ohio shall have exclusive jurisdiction for any disputes relating to this warranty.

Rev 03/2024