



Strong As An Ox™

BX2908 Installation Instructions 2004-07 Lexus GX470

Serial No.

The black plastic, front fascia, headlight brackets, headlight assembly, metal bumper and coolant line brackets are removed for baseplate installation. Drilling is required. Trimming of grill is required. The BX8869 is available for the vehicle. Attachment Tabs are 25 1/2 inches center to center and a height of 24 inches.



1. Remove the nine push pins from the radiator cover just forward of radiator and between headlight assemblies. **The 2007 model will have 12 pushpins to remove from radiator cover.**



2. Remove the three push pins from top edge of fascia and black plastic just between headlight assemblies.



3. Remove two push pins from power steering cover by depressing button in center of push pins, on passenger's side of engine compartment, pull black cover between headlights forward, set aside.

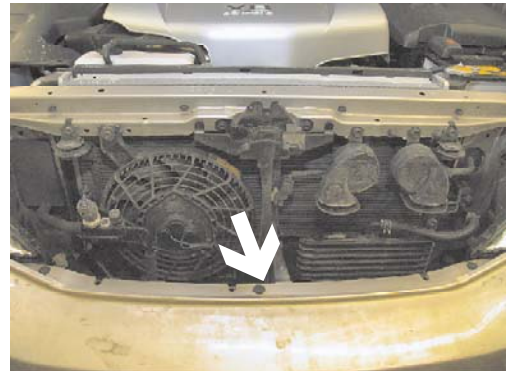

4. Remove the three push pins from top edge of fascia, just between headlight assemblies.

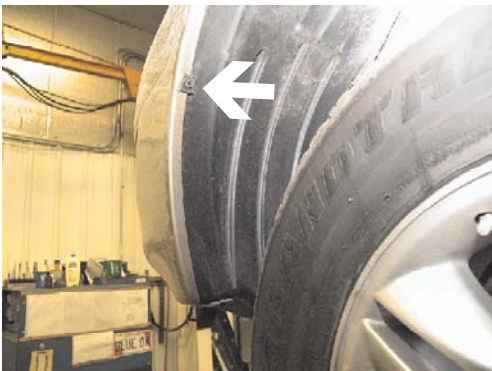

5. Using the 10MM socket, remove the metric bolt from edge of fascia, just forward of front tire, both sides.



6. Remove the metric bolt from the corner of fascia, just forward of front tire, with the 10MM socket, both sides.



Strong As An Ox™



7. Remove the three metric bolts from lower edge of fascia, just forward of front tire with the 10MM socket, both sides.

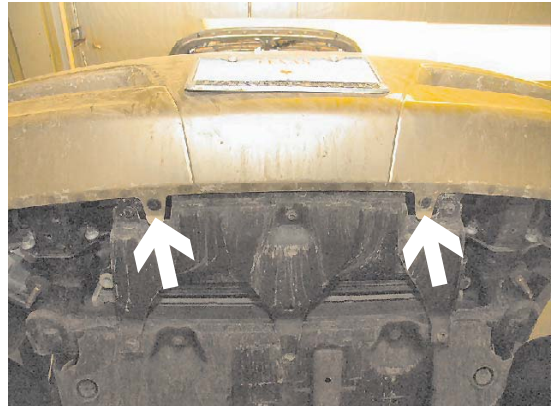

8. Remove the two metric bolts from lower edge of fascia just below license plate bracket, pull fascia corner out to the side, pull fascia forward and set aside.

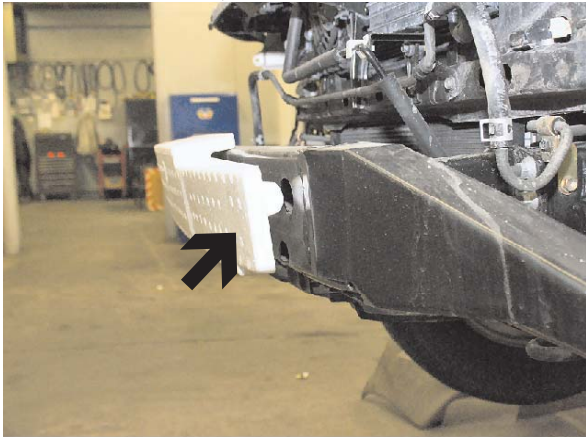

9. Remove styrofoam from the front of metal bumper and set aside. Remove the four metric bolts from the openings in front of metal bumper with the 14MM socket. Using the 10MM socket, remove the three metric bolts from the bottom of metal bumper and belly pan, pull bumper forward and set aside.

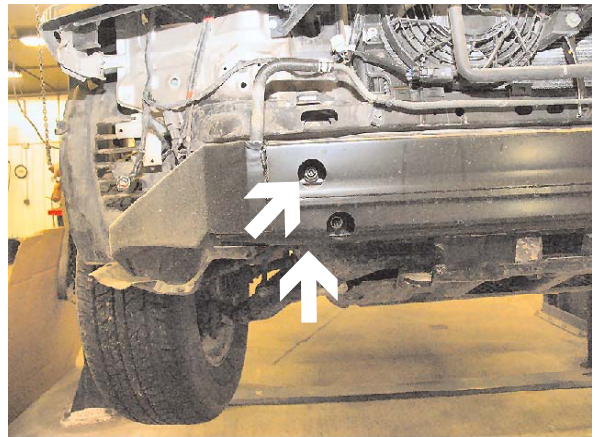

10. Using the 1 1/4" hole saw, cut a hole on the end of frame rail, both sides.



Strong As An Ox™

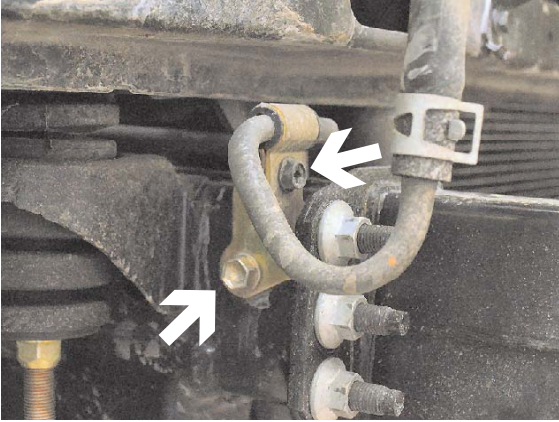

11. Remove the metric bolt from coolant line clamp with the 10MM socket, both sides. Remove the metric bolt from coolant line bracket with the 12MM socket on both sides, set clamp and bracket aside. Clamp and bracket will not be reinstalled.

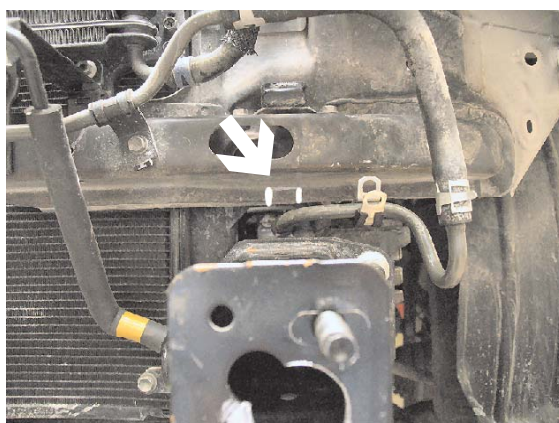

12. Mark ribbing just above and on each side and just above of coolant line. Pull coolant line down to frame and cut webbing from the bottom edge up about 1/2" on both sides of coolant line. Using the chisel and hammer, bend the webbing back toward radiator as far as possible. This will open area for the coolant line and eliminate erosion of tubing.

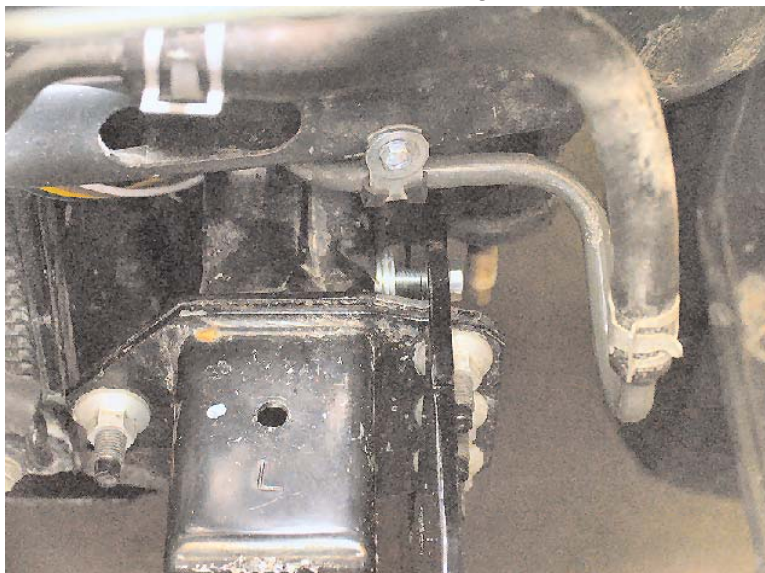

13. Snap loop clamp onto coolant line, lift clamp and coolant line up to the front side of cross member as far as possible, drill #10 x 1" self drill screw and 1/4" lock washer through clamp and into cross member, both sides. Be sure that coolant line does not touch bent webbing from step 12. This will open area for baseplate installation.



Strong As An Ox™

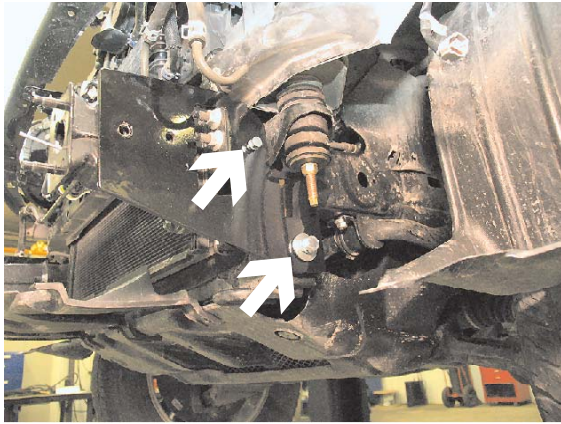

14. Place support plate onto the side of frame rail to align with the lower threaded hole on tie down support, just below frame rail. Install two 1/2" flat washers between tie down support and support plate, partially tighten 12MM hex bolt, 12MM lock washer and 1/2" flat washer into existing threaded hole, both sides. **Do not tighten completely.** Align hole of support plate with the existing threaded hole for coolant line bracket. Partially tighten the 8MM hex bolt and lock washer into hole of support plate while placing three 3/8" flat washers between support plate and frame, both sides. **Do not tighten completely.**

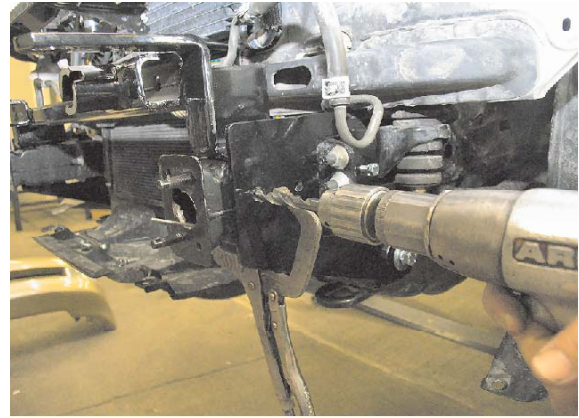

15. Place baseplate on the top of frame rail in between the side of the frame and the support plate. Align the holes of baseplate and support plate, clamp to frame with vise grip, both sides. Tighten the 12MM hex bolt with the 19MM socket and the 8MM hex bolt with the 13MM socket, both sides. Using the support plate and baseplate as a template, drill the two holes in the side of frame with the 13/32" drill bit, both sides. **Be sure and use loctite red on all bolts before tightening. Tighten all bolts according to torque chart in the General Instruction sheet.**

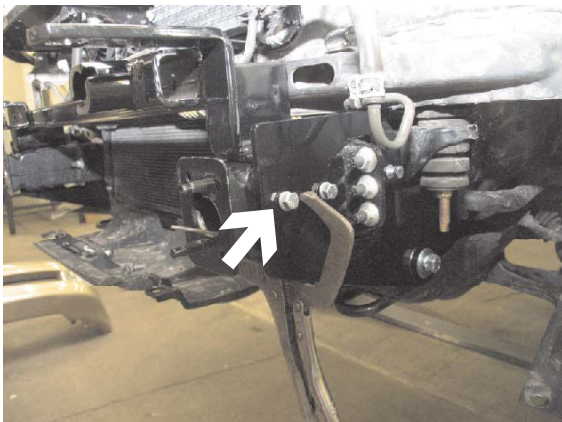

16. Insert the nut plates with wire into drilled hole in the end of frame from step 10, to align with drilled holes from the last portion of step 15. Tighten the 3/8-16 x 1 1/2" hex bolt and lock washer into drilled holes, both sides. **Be sure and use loctite red on all bolts before tightening. Tighten all bolts according to torque chart in the General Instruction sheet.**



17. Pry up small cover just behind headlight assembly, remove one metric bolt from under cover and one on top of radiator support with the 10MM socket, both sides.



Strong As An Ox™



18. Remove the three metric bolts from bracket on the side of headlight assembly with the 10MM socket, both sides.

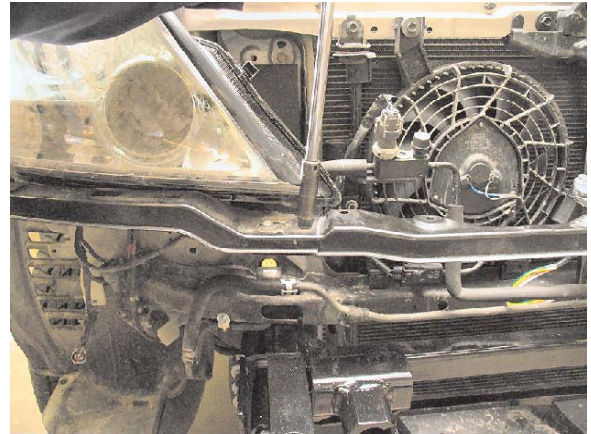

19. Remove the two metric bolts from bracket just below headlight assembly with the 10MM socket, both sides. Pull brace forward and set aside.



20. Release clip just behind headlight assembly, unplug electrical connections. Pull headlight assembly forward and set aside, both sides.

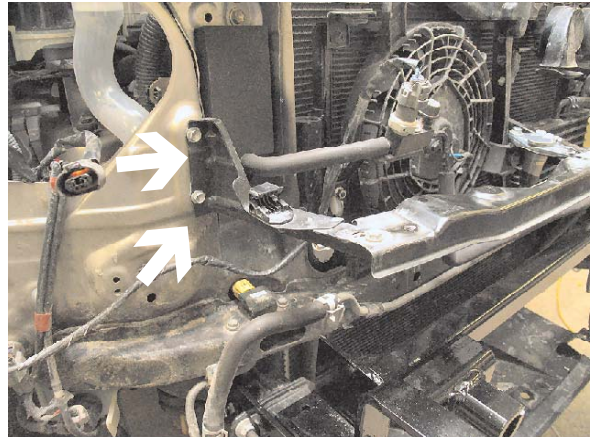

21. Remove the two metric bolt from bracket just behind headlight assembly with the 10MM socket, both sides and set brace aside. This will open area for drilling of baseplate holes.

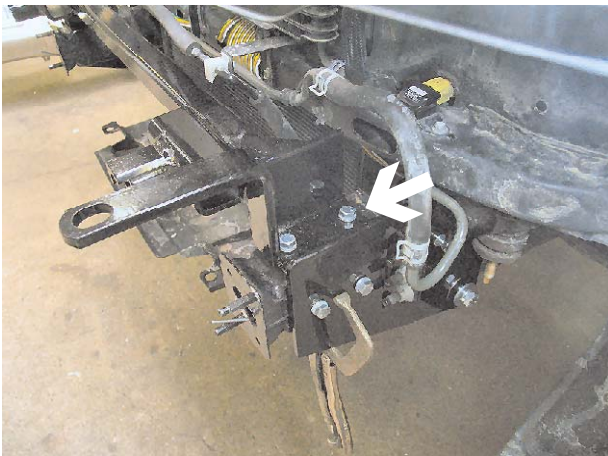

22. Using the baseplate as a template, drill the two remaining holes into frame with the 13/32" drill bit, both sides. Insert the nut plate with wire into drilled hole in the end of frame to align with drilled holes, tighten the 3/8-16 x 1 1/4" hex bolts and lock washers into drilled holes, both sides. **Be sure and use loctite red on all bolts before tightening. Tighten all bolts according to torque chart in the General Instruction sheet.**



Strong As An Ox™

- 23.** Reinstall headlight brackets, headlight assemblies, metal bumper, belly pan, styrofoam, and fascia. **Be sure all electrical components are plugged in properly.**
- 24.** The dimensional variations between otherwise identical cars can be considerable. While the baseplate was designed for easy installation, it may be necessary to tailor the baseplate slightly to compensate for auto manufacturers' tolerances. These minor adjustments may include filing a hole slightly, bending electrical rods, adding shims and/ or bending endplates.
- 25.** Install the tow bar and safety cables according to the instructions included in their packages.
- 26.** Do **not** substitute other devices if the tow bar pin and clip are lost.
- 27. DEALER OR INSTALLER: BE CERTAIN THE USER RECEIVES THE INSTRUCTION SHEET.**



Location for the electrical bracket.

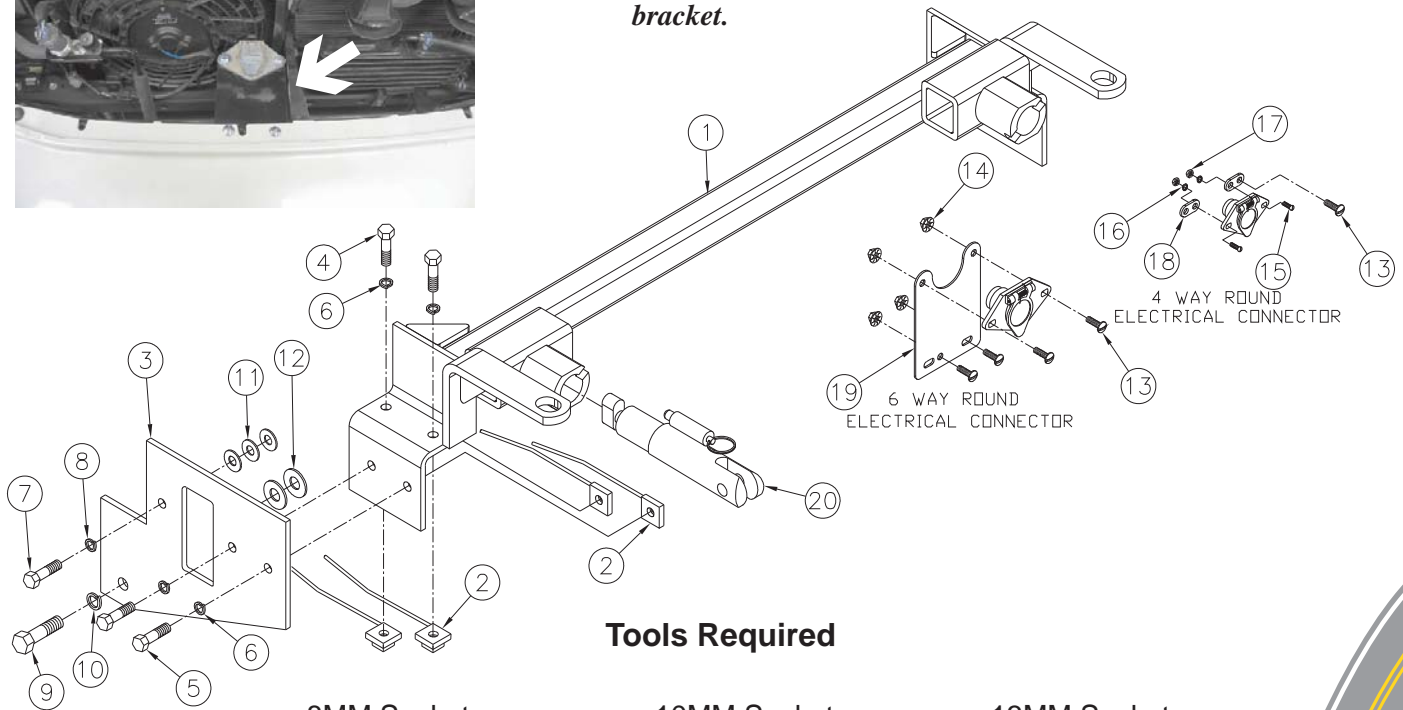

Tools Required

- | | | |
|-------------------|---------------|------------------|
| 8MM Socket | 10MM Socket | 13MM Socket |
| 14MM Socket | Loctite | 19MM Socket |
| Flat Screw Driver | Vise Grips | 9/16" Socket |
| 1 1/4" Hole Saw | Utility Knife | 13/32" Drill Bit |

IMPORTANT: Use only genuine factory replacement parts on your Base Plate. Do not substitute homemade or nontypical parts. If a bolt is lost or in need of replacement, for your safety and the preservation of your Base Plate, be sure to use a replacement bolt of the same grade (Usually Grade 5, refer to parts list). Repair parts may be ordered through your nearest **Blue Ox** dealer or distributor.



Strong As An Ox™

Parts List

Ref. No.	Qty.	Part No.	Description
1	1	61-6097	Weldment, Base Plate, BX2908
2	8	61-5208	3/8" Nut Plate, with 14" Wire
3	2	101-6721	Support Plate, BX3758
4	4	201-0368	3/8-16 x 1 1/4 Bolt, Grd. 5, ZP
5	4	201-0440	3/8-16 x 1 1/2 Bolt, Grd. 5, ZP
6	8	203-0010	3/8 Lock Washer, ZP
7	2	201-0446	8MM-1.25 x 30MM, Hex Bolt, Grd. 8 8, ZP
8	2	203-0102	8MM Lock Washer, ZP
9	2	201-0603	12MM-1.25 x 45MM, Hex Bolt, Grd. 8 8, ZP
10	2	203-0105	12MM Lock Washer, ZP
11	6	203-0003	3/8 Flat Washer, ZP
12	6	203-0005	1/2 Lock Washer, ZP
13	4	201-0111	1/4-20 x 3/4" Slot Truss Head Screw, ZP
14	4	202-0069	1/4-20, Whiz Nut, ZP
15	2	201-0192	#10-32 x 1/2 Slot, Rd. Hd. Screw
16	2	203-0054	#10 Lock Washer
17	2	202-0047	#10-32 Hex Nut
18	2	101-5822	Adapter, 4 Way Connector
19	1	101-6739	Bracket, Electrical, BX2908
20	2	62-3468	Attachment, Assembly, SF/ SB (R)
	2	201-0654	#10-16 x 1 Self Drilling Screw, ZP (Not Shown)
	2	203-0001	1/4" Flat Washer, ZP (Not Shown)
	2	225-0051	Clamp, Loop Clamp IMO (Not Shown)
	2	226-0046	Baseplate Safety Cable, 36" CL III (Not Shown)
	2	229-0359	Quicklink, 3/8, ZP (Not Shown)
	2	290-0437	Receiver, Cap Plug (BLK) (Not Shown)

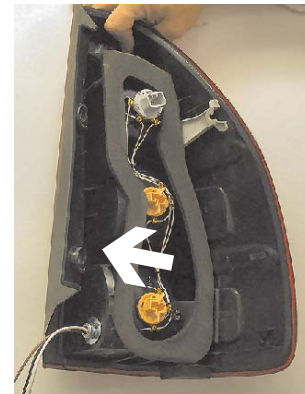

Location for the Bx8869 on driver's side tail light assembly.