

CLASS 4 TRAILER HITCH

R3-0480

Ford Ranger

TOOLS REQUIRED:

DRILLS: None

WRENCHES: Torque Wrench, Ratchet, C- Clamps

SOCKETS: 21mm, Socket Extension

HITCH RATING: 7,000 LBS WEIGHT CARRYING, 700 LBS TONGUE WEIGHT / 8,000 LBS WEIGHT DISTRIBUTING, 800 LBS TONGUE WEIGHT. WARNING: CONSULT VEHICLE OWNERS MANUAL FOR TOWING RECOMMENDATIONS. DO NOT EXCEED VEHICLE'S RECOMMENDED TOWING CAPACITY. THIS PRODUCT IS DESIGNED FOR TRAILER TOWING ONLY AND SHOULD NOT BE USED FOR ANY OTHER PURPOSE.

NOTE: INSTALL PARTS LOOSELY UNTIL ALL ATTACHMENTS HAVE BEEN MADE TO VEHICLE

Note: Hitch uses existing vehicle hardware. No other hardware is required.

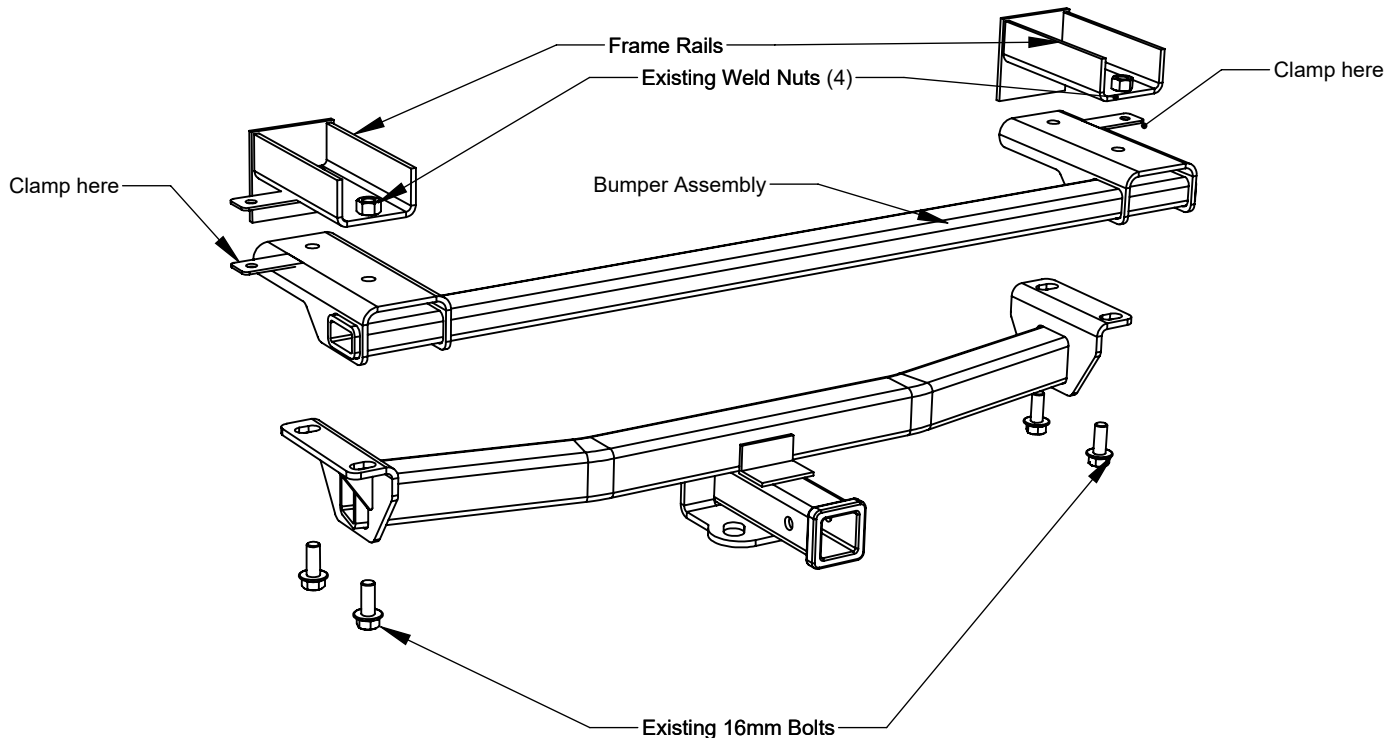

1. Clamp bumper assembly to frame rails at the outboard tabs (see illustration above).
2. Lower the spare tire to ease installation.
3. Remove the (4) 16mm hex bolts attaching the bumper assembly to the frame.
4. Raise the hitch into position and attach with the (4) 16mm bolts removed in step 2.
5. Center hitch on vehicle and tighten all fasteners to 196 ft-lbs.
6. Remove the clamps installed in step 1.
7. Raise the spare tire back into position.

Thank you for purchasing a Rigid Hitch

GIVE THIS INSTRUCTION SHEET TO VEHICLE OWNER



THIS PRODUCT COMPLIES WITH SAFETY SPECIFICATIONS AND REQUIREMENTS FOR SAE AND VESC REGULATION V-5 FOR CONNECTING DEVICES AND TOWING SYSTEMS. **DO NOT MODIFY THIS PRODUCT. INSTALL ONLY ON SPECIFIED VEHICLES IN GOOD CONDITION.**

RIGID[®]
HITCH INCORPORATED
3301 WEST BURNSVILLE PARKWAY
BURNSVILLE, MN 55337

REV.
6/19